

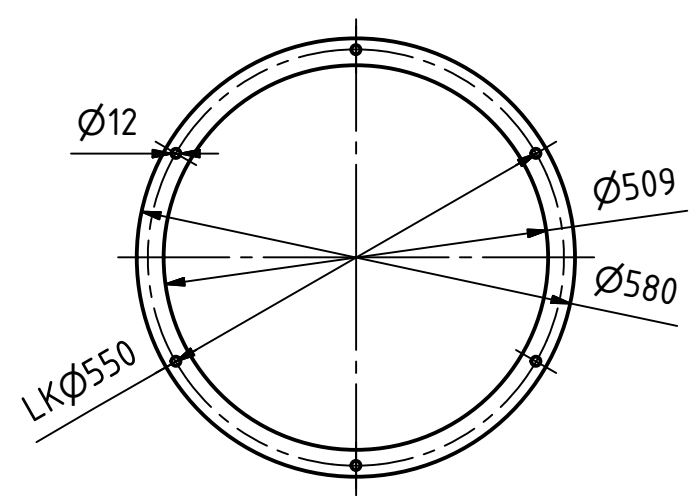

Outlet  
( 1 : 10 )

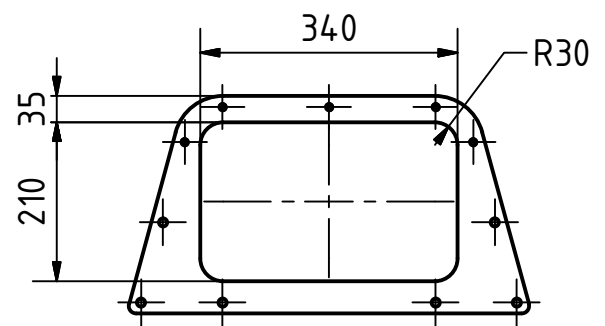

Inlet  
( 1 : 10 )



Specifications	
Size	1057 x 799 x 1222
Inlet	340 x 210
Outlet	Ø500
Motor	1,1 kW
Steam Inlet	1 1/2"
Weight	245 kg

 Streckel & Schrader KG Hinschenfelder Str. 35 22041 Hamburg Germany Tel.: 040 693 7077 Fax: 040 693 53 10 www.streckelschrader.de kontakt@streckelschrader.de	Werkstoff:	1.4301	
	Gezeichnet	04.03.2013	
	Kontrolliert		
	Norm		
Status	Änderungen	DATUM	Name

Maßstab: 1 : 15
Halbzeug: Gewicht: 245,000 kg
Benennung: <b>Round Steamer Type RD 500 V2</b>
Zeichnungs-Nr.: <b>013-00576</b>
1 A3