

A (1 : 20)

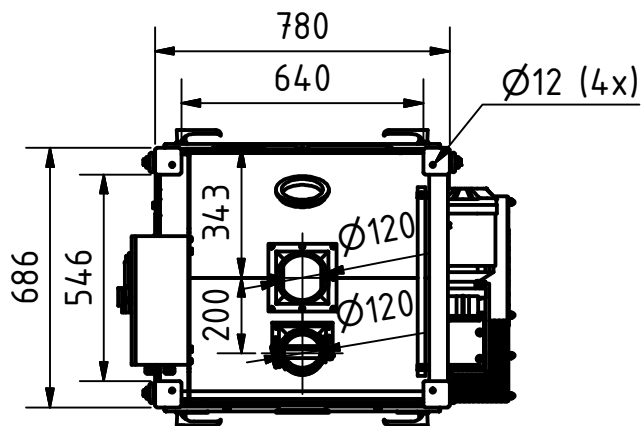

Specifications	
Size	1049 x 782 x 1461
Inlet	Ø100
Outlet	Ø100 / Ø120
Aspiration	Ø120
Motor	1,1 kW
Weight	418 kg



Streckel & Schrader KG
Hinschenfelder Str. 35
22041 Hamburg Germany
Tel.:040 693 7077 Fax:040 693 53 10
www.streckelschrader.de
kontakt@streckelschrader.de

Werkstoff:
Geschweißter Stahl (weich)

Maßstab: 1 : 20

Halbzeug:
Gewicht: -

Benennung:
Groat cutter
Type Krone 2 ATEX

Zeichnungs-Nr.:
013-00558

1
A3

Status	Änderungen	DATUM	Name

Gezeichnet	DATUM	Name
19.11.2012		Jeanine Streckel
Kontrolliert		
Norm		