

Specifications	
Size	6011 x 1503 x 3051
Inlet	995 x 250
Outlet	1025 x 305
Aspiration	Ø500
Motor	2x 0,55 kW
Warm Air V.	7,5 kW
Cold Air V.	2x 2,2 kW
Heat Exchanger Inlet	EN 1092-1/11/B1/DN50x2,9/PN40
Heat Exchanger Outlet	EN 1092-1/11/B1/DN32x2,6/PN40
Weight	2723 kg

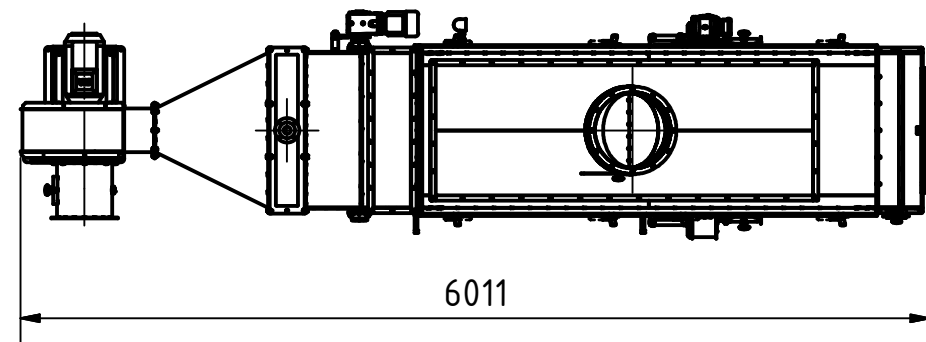

Inlet
A (1 : 25)

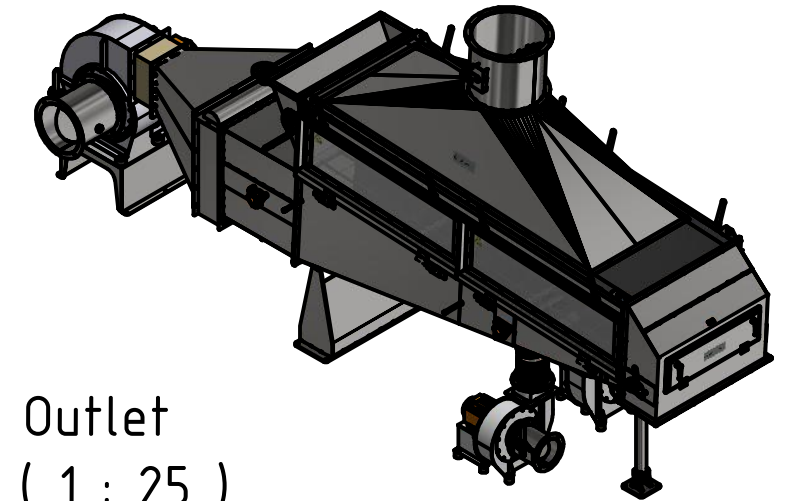
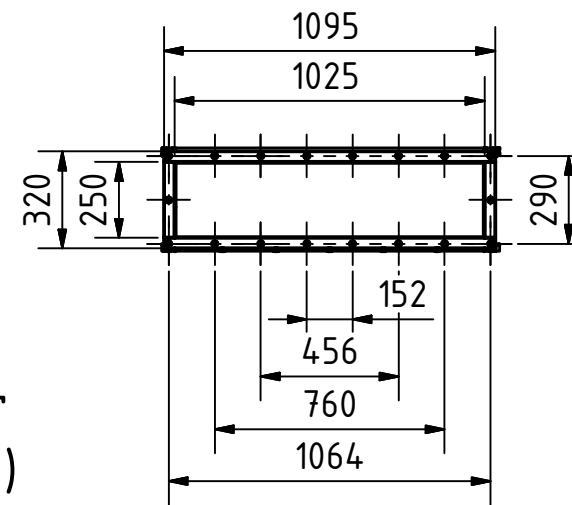

Outlet
B (1 : 25)

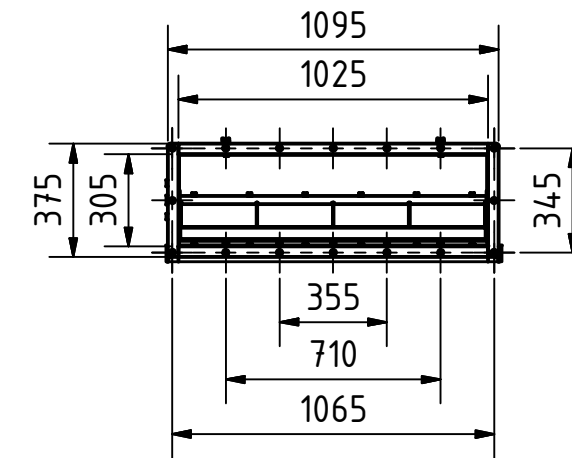

Warm Air
(1 : 20)

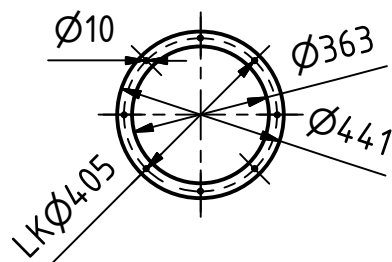

Aspiration
(1 : 20)

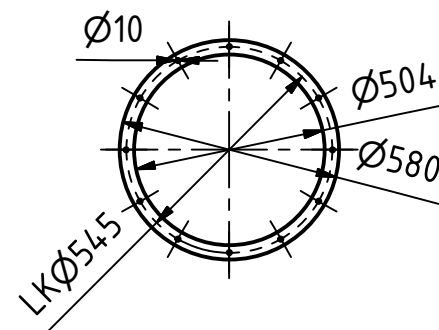

Cold Air
(1 : 20)

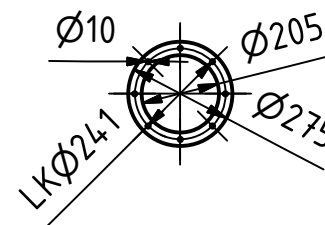

Streckel & Schrader GmbH & Co. KG
Hinschenfelder Str. 35
22041 Hamburg Germany
Tel.: 040 2880 340 10

Werkstoff:		Maßstab: 1 : 50	
DATUM		Name	
Gezeichnet: 26.11.2012		Bartelmann	
Kontrolliert:			
Norm:			
Status		Änderungen	
DATUM		Name	
Benennung:			1
Fluid bed drier Type			A3
WST 300 V2 DF with cold air			
Zeichnungs-Nr.:			
013-00696a			