

Specifications	
Size	6010 x 1503 x 3291
Inlet	860 x 255
Outlet	1025 x 305
Aspiration	Ø504
Motor	2x 0,55 kW
Warm Air V.	7,5 kW
Cold Air V.	2x 2,2 kW
Heat Exchanger Inlet	EN 1092-1/11/B1/DN50x2,9/PN40
Heat Exchanger Outlet	EN 1092-1/11/B1/DN32x2,6/PN40
Weight	1743 kg

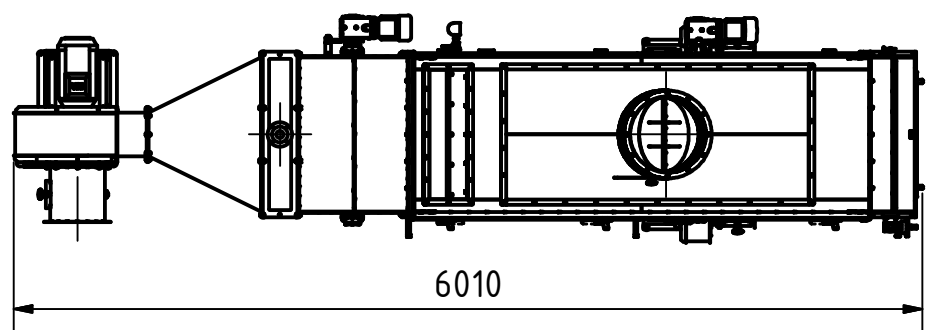

Inlet
(1 : 20)

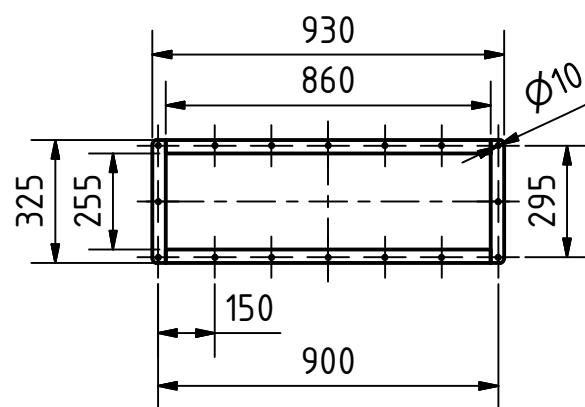

Outlet
(1 : 20)

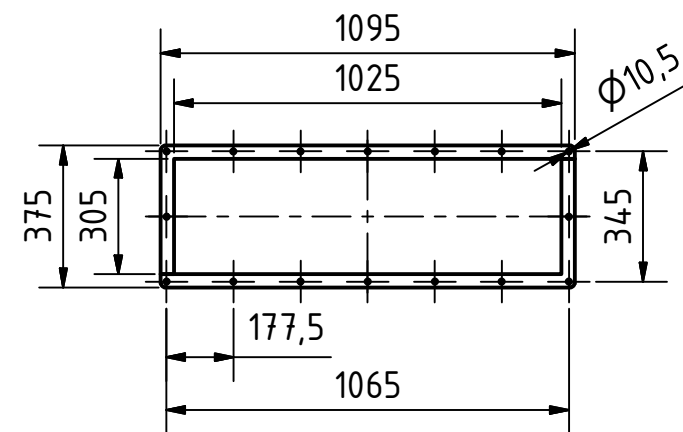

Warm Air
(1 : 20)

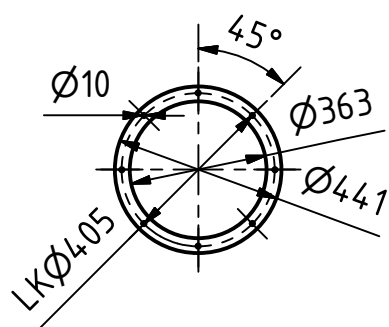

Aspiration
(1 : 20)

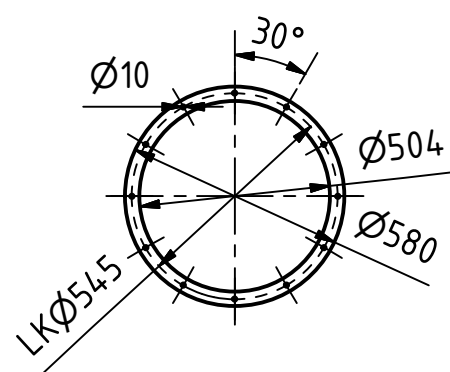

Cold Air
(1 : 20)

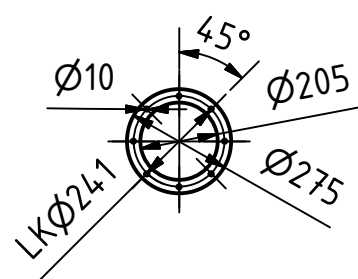

Streckel & Schrader KG
Hinschenfelder Str. 35
22041 Hamburg Germany
Tel.:040 693 7077 Fax:040 693 53 10
www.streckelschrader.de
kontakt@streckelschrader.de

Werkstoff:
Edelstahl

Maßstab: 1 : 50

Halbzeug:
Gewicht: 1743,000 kg

Gezeichnet	DATUM	Name
26.11.2012		Bartelmann
Kontrolliert		
Norm		

Benennung:
Fluid bed drier type
WST 300 with cold air

Zeichnungs-Nr.:
013-00008g

1
A3

Status	Änderungen	DATUM	Name