

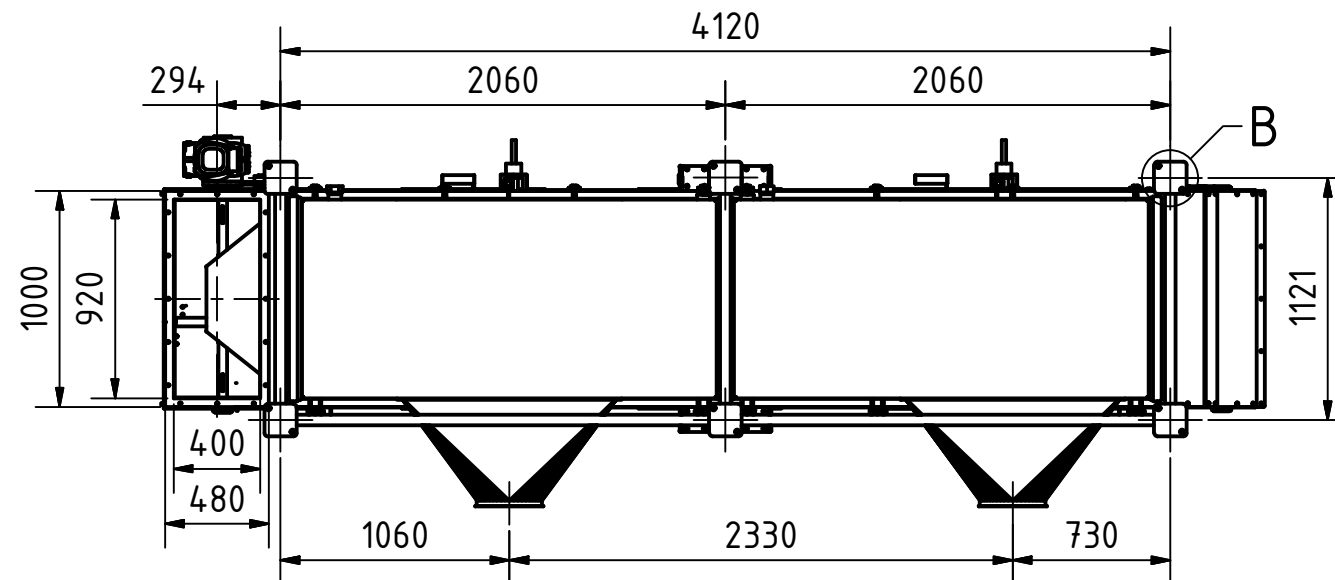

A (1 : 35)

B (1 : 10)

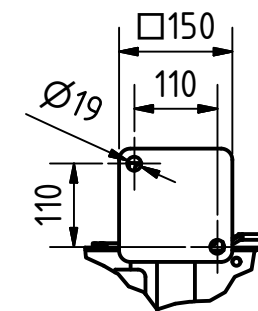

Specifications	
Size	5109 x 1713 x 1086
Inlet	$\varnothing 300$
Outlet	920 x 400
Aspiration	4x $\varnothing 300$ / 2x $\varnothing 300$
Motor	0,37 kW
Weight	1300 kg

 Streckel & Schrader GmbH & Co. KG Hinschenfelder Str. 35 22041 Hamburg Germany Tel.: 040 2880 340 10	Werkstoff: Edelstahl	Maßstab: 1 : 35	
		Halbzeug: Gewicht: -	
	DATUM	Name	Benennung: Cooling belt conveyor 5 m with aeration floor
	Gezeichnet 18.10.2019	Bartelmann	
	Kontrolliert		
	Norm		Zeichnungs-Nr.: 019-00253a
Status	Änderungen	DATUM	Name