

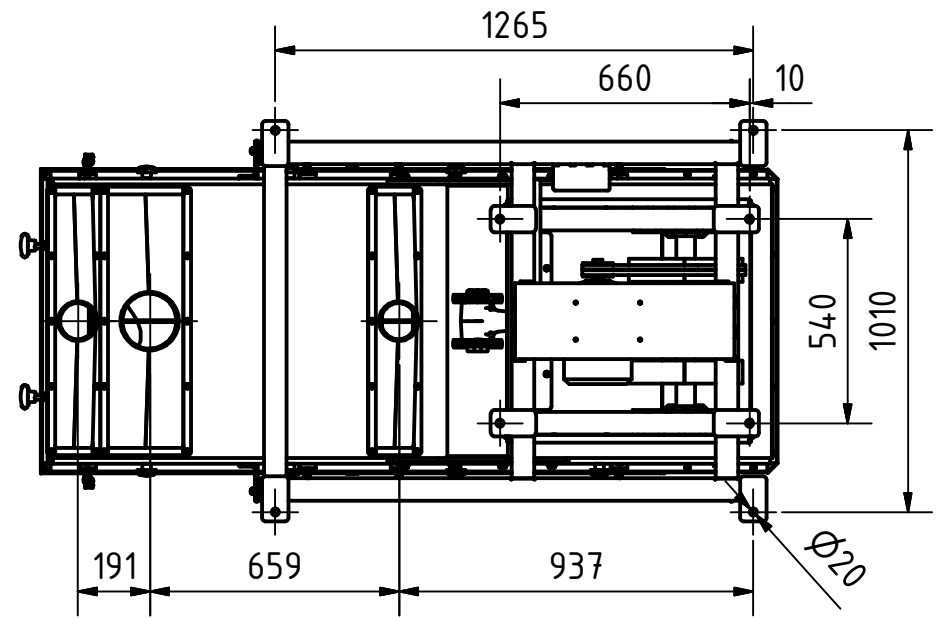

A (1 : 20)



Specifications	
Size	2004 x 1060 x 798
Inlet	750 x 250
Outlet	Ø150 / 2x Ø100
Motor	0,75 kW
RPM	1000 min ⁻¹
Weight	286 kg

 Streckel & Schrader KG Hinschenfelder Str. 35 22041 Hamburg Germany Tel.: 040 693 7077 Fax: 040 693 53 10 www.streckelschrader.de kontakt@streckelschrader.de	Werkstoff:		Maßstab: 1 : 20	
	Gezeichnet: 20.11.2013		Name: Bartelmann	
Kontrolliert:		Benennung: Control sieve Type KS 750x1500		
Norm:		Zeichnungs-Nr.: 013-00202a		
Status	Änderungen	DATUM	Name	1 A3