

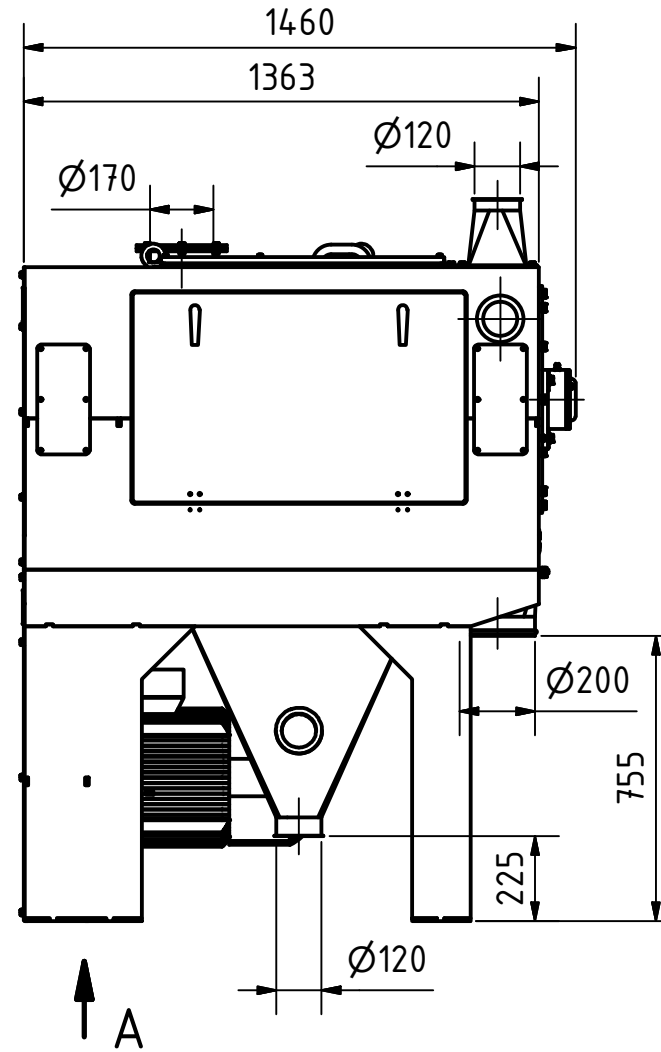

A (1 : 20)

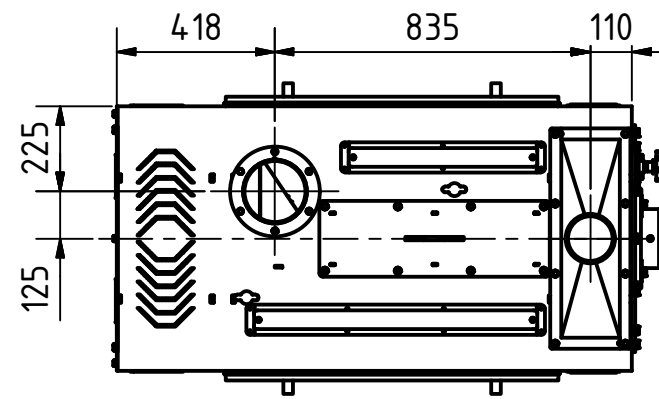

A

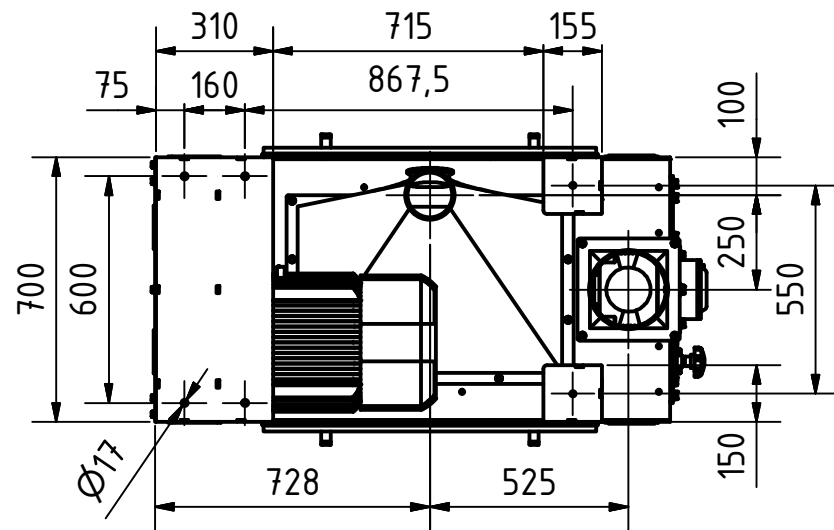
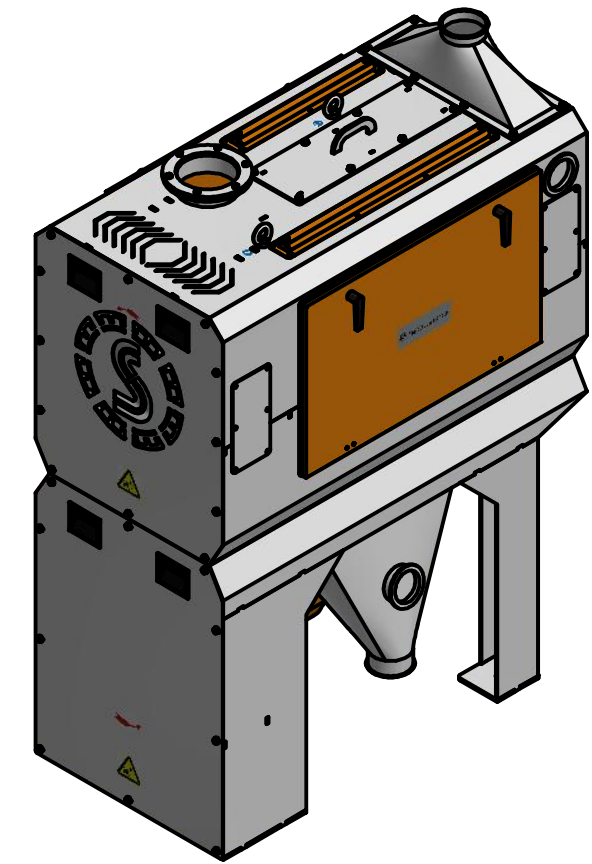

Technische Daten	
Größe	1460 x 822 x 1910
Einlauf	Ø170
Auslauf	Ø200 / Ø120
Aspiration	Ø120
Motor	15 kW
Gewicht	940 kg

 Streckel & Schrader GmbH & Co. KG Hinschenfelder Str. 35 22041 Hamburg Germany Tel.: 040 2880 340 10	Werkstoff:		Maßstab: 1 : 20	
	Gezeichnet		Halbzeug:	
DATUM		Name		Benennung:
22.10.2019		Bartelmann		
Kontrolliert				
Norm				Horizontale Scheuermaschine Typ HSM 45-80
Status		Änderungen		Zeichnungs-Nr.:
DATUM		Name		
				013-00261a
				1
				A3