

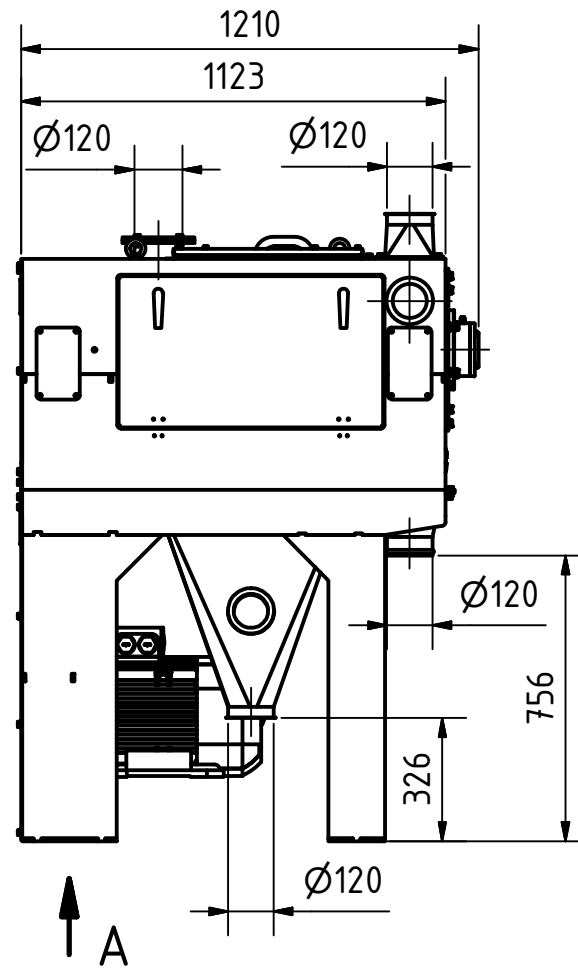

A ( 1 : 20 )

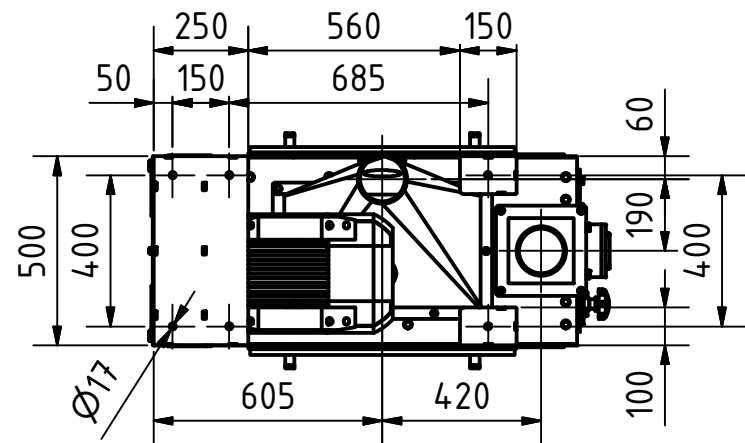

A

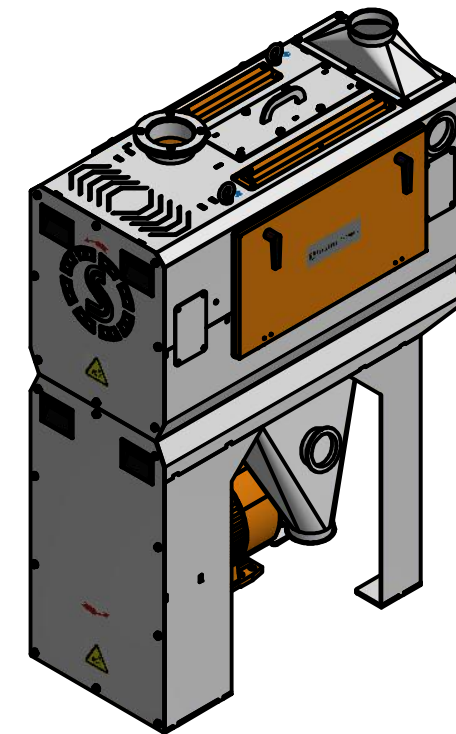
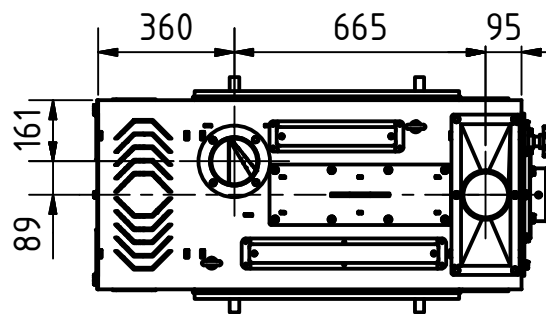

Technische Daten	
Größe	1210 x 622 x 1660
Einlauf	Ø120
Auslauf	Ø120 / Ø120
Aspiration	Ø120
Motor	11 kW
Gewicht	830 kg

 Streckel & Schrader GmbH & Co. KG Hinschenfelder Str. 35 22041 Hamburg Germany Tel.: 040 2880 340 10	Werkstoff:		Maßstab: 1 : 20	
	Gezeichnet 24.10.2019		Halbzeug: Gewicht: -	
DATUM		Name		Benennung: <b>Horizontale Scheuermaschine Typ HSM 30-60</b>
Kontrolliert		Bartelmann		
Norm				
Zeichnungs-Nr.:			013-00257a	
Status	Änderungen	DATUM	Name	1 A3