

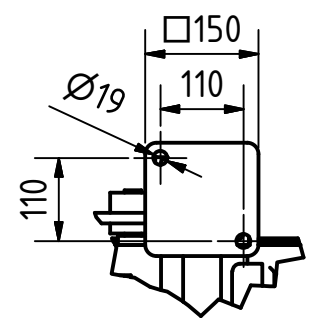

B ( 1 : 10 )



Technische Daten	
Größe	5443 x 2310 x 10118
Einlauf	Ø150
Auslauf	920 x 400
Aspiration	Ø120 / 4x Ø150 / 4x Ø300 / 2x Ø300
Motor	1,1 / 0,37 kW
Gewicht	150 / 245 / 4650 / 1300 kg

 Streckel & Schrader GmbH & Co. KG Hinschenfelder Str. 35 22041 Hamburg Germany Tel.: 040 2880 340 10	Werkstoff:	Maßstab: 1 : 70
		Halbzeug: Gewicht: -
	DATUM	Name
	Gezeichnet 16.04.2015	Bartelmann
	Kontrolliert	
	Norm	
		Benennung:
		Haferdarre (zwei Darrschächte) mit Dämpfer und Kühlband
		Zeichnungs-Nr.:
		019-00385
Status	Änderungen	DATUM
		Name
		1
		A3