

Einlauf
A (1 : 25)

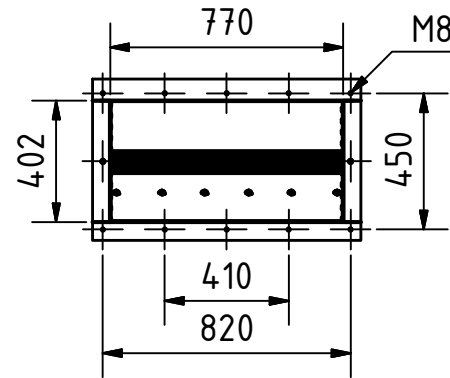

Auslauf
B (1 : 25)

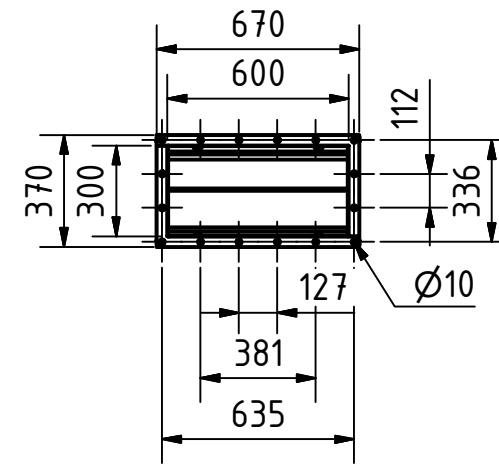

Technische Daten

Größe	2047 x 2833 x 1554
Einlauf	770 x 400
Auslauf	600 x 300
Aspiration	Ø150
Motor	22 / 1,1 / 0,55 / 0,12 kW
Gewicht	5139 kg



Streckel & Schrader GmbH & Co. KG
Hinschenfelder Str. 35
22041 Hamburg Germany
Tel.: 040 2880 340 10

Werkstoff:
Edelstahl

Maßstab: 1 : 25

Halbzeug:
Gewicht: -

Benennung:
**Flockenwalzenstuh Typ
FWS 500x800 mit E-Verstellung**

Zeichnungs-Nr.:

013-00761

1

A3

Status	Änderungen	DATUM	Name

Gezeichnet	DATUM	Name

Kontrolliert

Norm