

Einlauf  
A ( 1 : 25 )

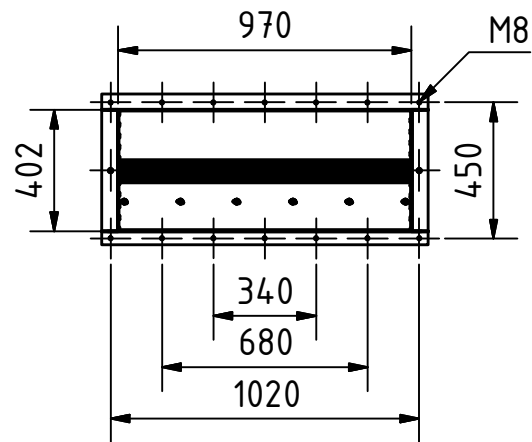

Auslauf  
B ( 1 : 25 )

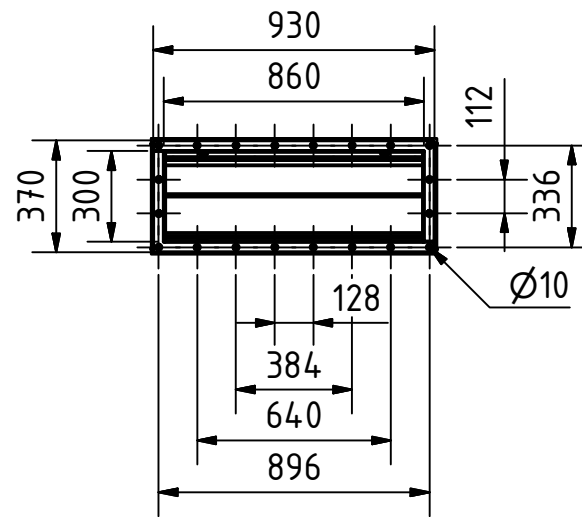

Technische Daten	
Größe	2247 x 2852 x 1554
Einlauf	970 x 400
Auslauf	860 x 300
Aspiration	Ø150
Motor	30 / 1,1 / 0,55 / 0,12 kW
Gewicht	5764 kg



Streckel & Schrader GmbH & Co. KG  
Hinschenfelder Str. 35  
22041 Hamburg Germany  
Tel.: 040 2880 340 10

Werkstoff:  
Edelstahl

Maßstab: 1 : 25  
Halbzeug:  
Gewicht: 5764,243 kg

Benennung:  
**Flockenwalzenstuhl Typ  
FWS 500x1000 mit E-Verstellung**

Zeichnungs-Nr.:  
**013-00730**

1  
A3

Status	Änderungen	DATUM	Name

DATUM	Name
Gezeichnet 26.10.2015	Bartelmann
Kontrolliert	
Norm	